



HANGCHA GROUP CO., LTD.

Factory site: 666 Xiangfu Road, Hangzhou, Zhejiang, China (311305)

Tel: +86-571-88926735 88926755
Fax: +86-571-88926789 88132890

sales@hcforklift.com
www.hcforklift.com



Follow us on Facebook



Follow us on YouTube



Follow us on WeChat



Download "Hangcha Forklift" App



ISO45001:2018



ISO14001:2015



ISO9001:2015



HANGCHA trucks conform to the European Safety Requirements.

2024 VERSION 2/COPYRIGHT 2024/08

HANGCHA GROUP CO., LTD. reserves the right to make any changes without notice concerning colors, equipment, or specifications detailed in this brochure, or to discontinue individual models. The colors of trucks, delivered may differ slightly from those in brochures.

XC Series 4-W Electric Forklift Truck With Lithium Iron-Phosphate

with capacity of 2,000 to 3,500kg



The World of Hangcha
SINCE 1956



INNOVATIVE SOLUTIONS NEW POWER NOW



The XC series new energy electric forklifts, covering range from 2.0t to 3.5t, is a series of products with new chassis launched by HANGCHA.

Innovative, reliable lithium-ion technology, which are developed jointly by HANGCHA and CATL. Battery cells and modules are from CATL, with reliable quality, exclusively for HANGCHA.

Rapid charging and opportunity charging ensure continuous availability of trucks. Lightweight design, flexible, high level of energy efficiency, maintenance-free, long service life.

EVE battery packs

		Battery capacity (kW-h)
Pack1	2.0 - 2.5t	76.8V*230Ah, 17.66kWh
Pack2	2.0 - 2.5t	76.8V*304Ah, 23.34kWh
Pack3	2.0 - 2.5t	76.8V*460Ah, 35.32kWh
Pack4	3.0 - 3.5t	76.8V*304Ah, 23.34kWh
Pack5	3.0 - 3.5t	76.8V*460Ah, 35.32kWh
Pack6	3.0 - 3.5t	76.8V*560Ah, 43.00kWh
Pack7	3.0 - 3.5t	76.8V*608Ah, 46.69kWh



High capacity CATL battery packs

Integrated Battery Management System (BMS) continually monitors energy management and ensures reliable operation. HANGCHA provides Li-Ion battery with 6 years or 12000 hours warranty.

		Battery capacity (kW-h)
Pack1	2.0 - 2.5t	80V*228Ah, 18.24kWh
Pack2	3.0 - 3.5t	80V*302Ah, 24.16kWh
Pack3	2.0 - 2.5t	80V*302Ah, 24.16kWh
Pack4	2.0 - 2.5t	80V*456Ah, 36.48kWh
Pack5	3.0 - 3.5t	80V*456Ah, 36.48kWh
Pack6	3.0 - 3.5t	80V*604Ah, 48.32kWh

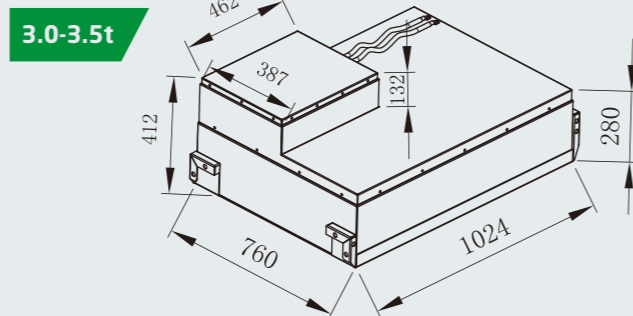
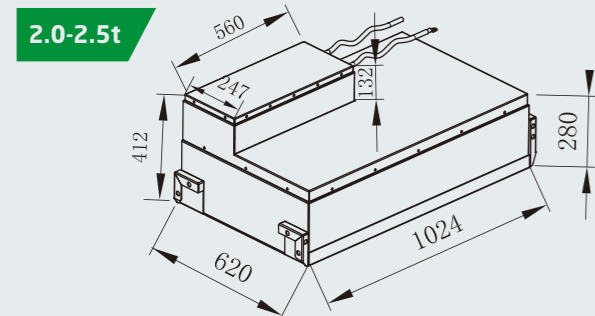

Excellent Ergonomic Design

- / The truck has a large operating space more than **50%** larger than the traditional electric truck.
- / The dashboard in the driver's cab is placed overhead and can be seen when the driver lifts her/his head, and the function buttons can be pressed easily.
- / For the optional integrated fingertip control system, the combined operating armrest integrates the emergency cut-off, horn and quadruple thumb switches, etc., is electrically controlled through the CAN bus and is highly reliable.
- / The enlarged brake pedal and appropriate regenerative braking function can effectively reduce the driver's fatigue.



Advantages



The rear axle is provided with a flexible suspension system (for standard configuration and automatic deceleration at turns improve the driver's comfort).

The high-frequency MOSFET integrated controller ensures smooth and accurate driving and lifting control, and has excellent speed regulation performance, good performance of electronic control matching the motor, functions of regenerative braking, reverse braking and anti-sliding on ramps, etc., and high safety and reliability.

The ultra-high power AC traction motor has a bridge structure. An ultra-high power AC pump motor is used. The system has high efficiency, complete protection functions, built-in speed and temperature sensors, and greatly improved reliability and life.

RELIABLE TRUCKS



6 YEARS WARRANTY

Easy operations and maintenance

Internal Components Protected with Fully-sealed Hood, controllers, motors electrical components, etc. are sealed from dust and water.



The hood can be opened at a large angle facilitating the maintenance.



IPX4 water resistance rating, suitable for outdoor operation



FIMS

FLEET INTELLIGENT MANAGEMENT SYSTEM

MOBILE SOLUTION PROVIDING A MOBILE APPLICATION



KEEP AN EYE ON EVERYTHING

Hangcha FIMS is a system that provides you with real-time information about forklift truck and driver. Whether you have dozens or hundreds of forklift trucks across multiple sites, you can get access to collecting, monitoring and evaluating all the fleet data at anytime and anywhere.

» Features

- ▶ Access Control
- ▶ GPS Tracking
- ▶ Remote Monitoring
- ▶ Maintenance Reminder
- ▶ Vehicle Management
- ▶ Vibration Monitoring
- ▶ Pre-shift Check (Optional)
- ▶ Shift Management (Optional)
- ▶ OpenAPI (Optional)



Safety

The optional OPS system can disable the lowering when the driver leaves the seat and enable high safety.

The standard configuration provides soft landing system. In addition, an optional lift buffering system is provided to protect the goods from falling and damaging the ground.

The handbrake can be optionally equipped with an alarm buzzer to prompt the driver to pull up the handbrake before leaving the truck.



Three horn buttons are provided, which are respectively on the driver's steering wheel, thumb switch equipped armrest (optional) and reverse armrest (optional), for alerting and protecting the surrounding people.



A PIN code should be provided before entering the system. 99 sets of PIN codes are available for the administrator. The truck is highly secured and irrelevant personnel cannot start the truck.



IP67 Protection Rating



Quick charge < 2.0h

Comfort

Owing to the low center of gravity and good stability, the driver feels comfortable during turning.

The ergonomically designed adjustable steering wheel makes the driver feel good. The seat can be adjusted back and forth by 210mm. The operator can choose the best driving position.

New designed mast increases the wide view by 15%.

With friendly human-computer interfaces, the 4.33" True Color Screen instruments have good visibility and clear readings.

Silence, no pollution, energy saving and other advantages meet the environmental protection requirements.



Grammer fingertip (Optional)



Main Accessories

The main electrical components such as the controller, contactor, power plug, emergency cut-off switch, dashboard, accelerator, are all products of well-known world brands.

The emergency cut-off switch equipped for the standard configuration complies with EU regulations.

The truck has passed the CE certification.



Options

- / Lithium packs that can be replaced quickly
- / Pin code or card
- / Super elastic tyre
- / Marked solid tyre
- / Left and right rear view mirrors
- / Backup camera
- / Front/rear blue lights
- / Rear working lights
- / Charger (Titan or Schneider)
- / Reverse armrest
- / Hood with a key lock
- / OPS system
- / Lift buffering system
- / Multi way valves
- / Integrated fingertip control system
- / Widened / heightened load backrest
- / Widened fork carriage
- / Other length forks
- / Full free duplex mast
- / Full free triplex mast
- / Sideshifter
- / Other attachments
- / Grammer MSG531 suspension seat
- / Automatic deceleration at turns
- / FIMS(Fleet intelligent management system)

Standard specification

- / Lithium packs with low temperature electric heating systems
- / High-power AC drive motor
- / High-power AC pump motor
- / Low noise gear pump
- / Multi-function color screen instrument cluster
- / Large integral rubber pedal pad
- / LED combination headlights, LED rear combination taillights
- / Stamped iron hood
- / Soft landing system
- / SPE power selection
- / Charging muzzle meeting national standards
- / Electronic cooling fan
- / Emergency cut-off switch
- / Reversing buzzer
- / Traction pin
- / Folder
- / Load sensing steering system
- / Duplex mast
- / Tilt cylinder jacket



35

Li-ION BATTERY
HANGCHA

HANGCHA
Li-ION BATTERY